

## PRINT INSTALLATION

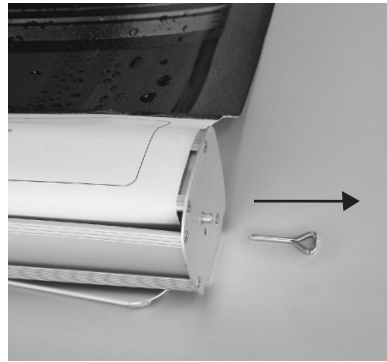

1. Keep print(s) taut while installing into the clamping rail(s). The front of the print(s) must face the same direction as the front of the clamping rail(s). Insert end caps.

2. Line the bottom of the print(s) up with the adhesive on the insert of the base. The front of the print must face up.

3. Hold the print tightly while removing locking pin. Allow print to roll into the base slowly. For DS model, be sure to do one print at a time after locating the two pins on either side of the base.

## ASSEMBLY AFTER PRINT INSTALLATION

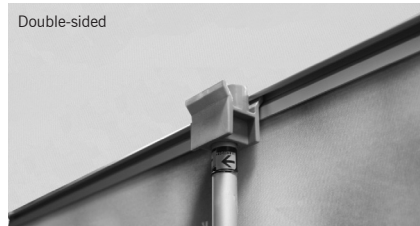
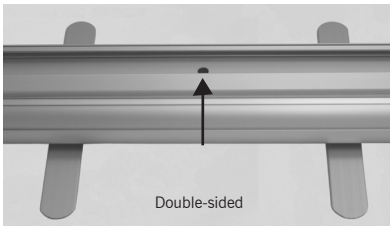
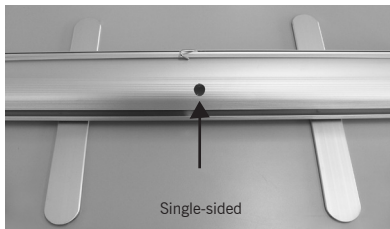

1. Locate the feet under the base and slide straight out. Assemble the 3-part pole and place into the socket found on the top center of the base.

2. Pull clamping rail with print out of the base and insert the 3-part pole into the notch of the clamping rail. For DS model, repeat with other print.

## REMOVAL OF PRINT

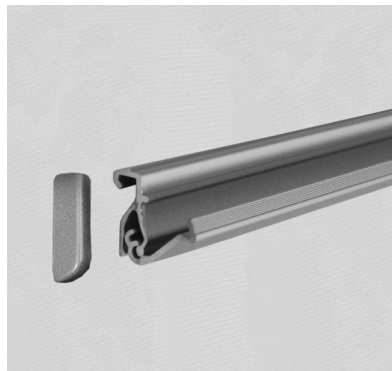
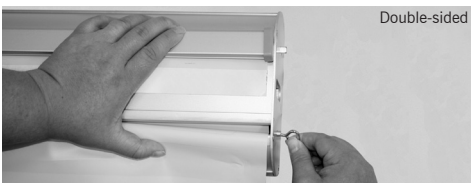
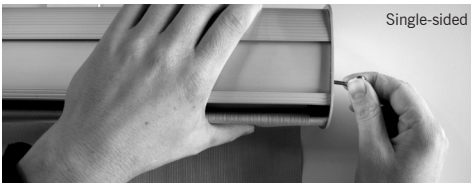

1. Pull clamping rail and print out of the base. Insert the locking pin into the small hole located on the side of the base. For DS model, repeat with other print and corresponding hole.

2. Remove the end caps from the clamping rail(s) and take out the print(s). Pull the print(s) off of the adhesive on the base. If installing a new print, replace the adhesive.



AMERICA'S SUPERSTORE FOR CHURCH BANNERS, DISPLAY SYSTEMS & INSPIRATIONAL PRODUCTS

PO Box 1024 | Gallatin Tennessee 37066-1024 USA | 615.206.8400 or 615.395.8024 | customerservice@banners4churches.com  
www.banners4churches.com | banners4churches.printesto.com